

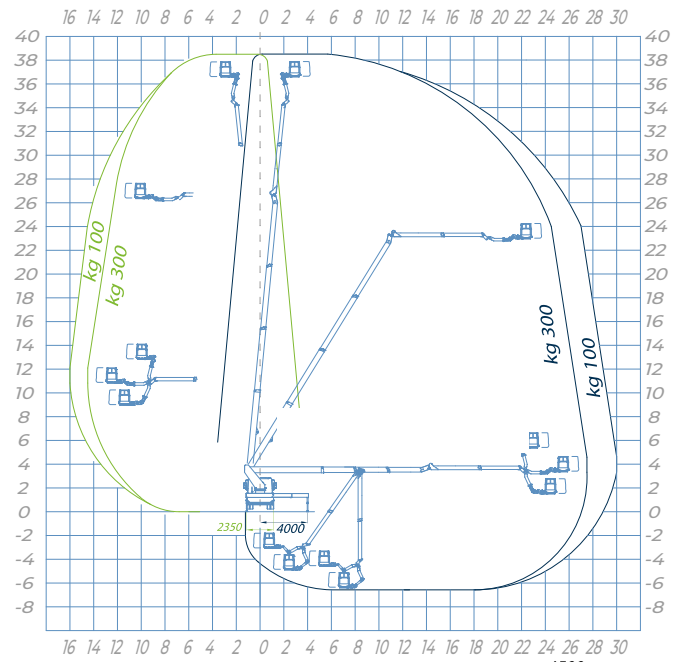

ALTEZZA DI LAVORO	38,5 m
ALTEZZA PIANO CALPESTIO	36,5 m
SBRACCIO MAX DI LAVORO	30 m
ROTAZIONE TORRETTA	700°
ROTAZIONE IDRAULICA DEL CESTELLO	± 90°
DIMENSIONE MAX DEL CESTELLO	2,2/3,2 x 0,9 x 1,1
PORTATA CESTELLO	300 kg

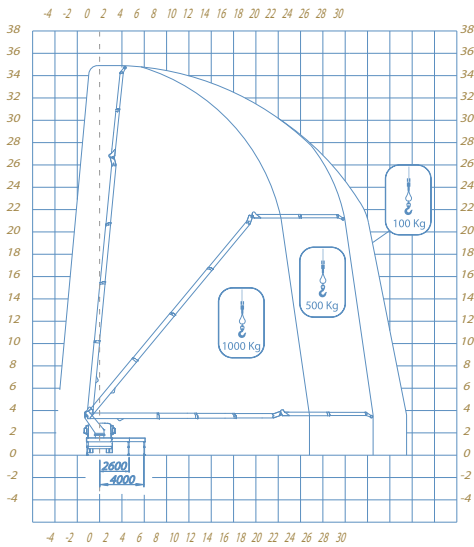

- Area di lavoro con stabilizz. in sagoma
- Area di lavoro massima

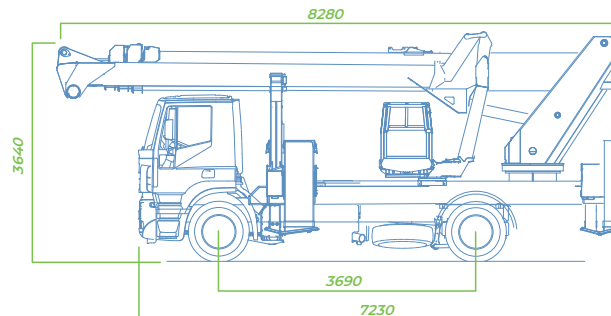
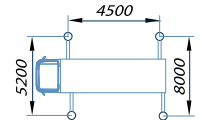

Misure su Iveco Eurocargo