

CHARACTERISTICS			
1.1	Manufacturer (abbreviation)		Mitsubishi Forklift Trucks
1.2	Manufacturer's model designation		FB18ACN
1.3	Power source: (battery, diesel, LP gas, petrol)		Electric
1.4	Operator type: pedestrian, (operator)-standing, -seated		Seated
1.5	Load capacity	Q kg	1800
1.6	Load center distance	c mm	500
1.8	Load distance, axle to fork face	x mm	343
1.9	Wheelbase	y mm	1394
WEIGHT			
2.1	Truck weight, without load / including battery (simplex mast, lowest lift height)	kg	3114
2.2	Axle loading with maximum load, front / rear (simplex mast, lowest lift height)	kg	4311 / 603
2.3	Axle loading without load, front / rear (simplex mast, lowest lift height)	kg	1422 / 1692
WHEELS, DRIVE TRAIN			
3.1	Tyres: V=solid, L=pneumatic, SE=solid pneumatic - front / rear		SE
3.2	Tyre dimensions, front		18 x 7-8
3.3	Tyre dimensions, rear		16 x 6-8
3.5	Number of wheels, front / rear (x=driven)		2 x / 2
3.6	Truck width (center of tyres), front	b10	930
3.7	Truck width (center of tyres), rear	b11	898
DIMENSIONS			
4.1	Mast tilt, forwards / backwards	α/β °	5/7.5
4.2	Height with mast lowered (see tables)	h1 mm	2125
4.3	Free lift (see tables)	h2 mm	80
4.4	Lift height (see tables)	h3 mm	3290
4.5	Overall height with mast raised	h4 mm	4335
4.7	Height to top of overhead guard	h6 mm	2050
4.8	Seat height	h7 mm	1035
4.12	Tow coupling height	h10	520
4.19	Overall length	l1 mm	3152
4.20	Length to fork face (includes fork thickness)	l2 mm	2002
4.21	Overall width	b1/b2	1090
4.22	Fork dimensions (thickness, width, length)	s / e / l	35 x 100 x 1150
4.23	Fork carriage to DIN 15 173 A/B/no		2A
4.24	Fork carriage width	b3 mm	920
4.31	Ground clearance under mast, with load	m1 mm	95
4.32	Ground clearance at center of wheelbase, with load (forks lowered)	m2 mm	95
4.33	Working aisle width with 1000 x 1200 mm pallets, crosswise	Ast mm	3333
4.34a	Working aisle width with 800 x 1200 mm pallets, lengthwise	Ast mm	3456
4.35	Turning circle radius	Wa mm	1662
4.36	Minimum distance between centers of rotation	b13	0
PERFORMANCE			
5.1	Travel speed, with / without load	km/h	17 / 17
5.2	Lifting speed, with / without load	m/s	0.46 / 0.62
5.3	Lowering speed, with / without load	m/s	0.56 / 0.56
5.5	Rated drawbar pull, with / without load	N	4800 / 5100
5.6	Maximum drawbar pull, with / without load (5 min short duty)	N	14900 / 15200
5.7	Gradeability, with / without load	%	14 / 23
5.8	Maximum gradeability, with / without load	%	26 / 35
5.9	Acceleration time (10 metres) with / without load	s	4.2 / 3.8
5.10	Service brakes (mechanical / hydraulic / electric / pneumatic)		electric
ELECTRIC MOTORS			
6.1	Drive motor capacity (60 min. short duty)	kW	2 x 5.5
6.2	Lift motor output at 15% duty factor	kW	10
6.3	Battery to DIN 43 531 / 35 / 36 A/B/C/no		DIN 43531 A/no
6.4	Battery voltage/capacity at 5-hour discharge	V/Ah	500-625
6.5	Battery weight	kg	679 4.2
6.6a	Energy consumption according to EN 16796	kWh/h	
MISCELLANEOUS			
8.1	Type of drive control		AC
10.1	Maximum operating pressure for attachments	bar	210
10.2	Oil flow for attachments	l/min	30
10.7	Noise level, value at operator's ear (EN 12053)	dB(A)	65
10.8	Towing coupling design / DIN type, ref.		DIN15170-H

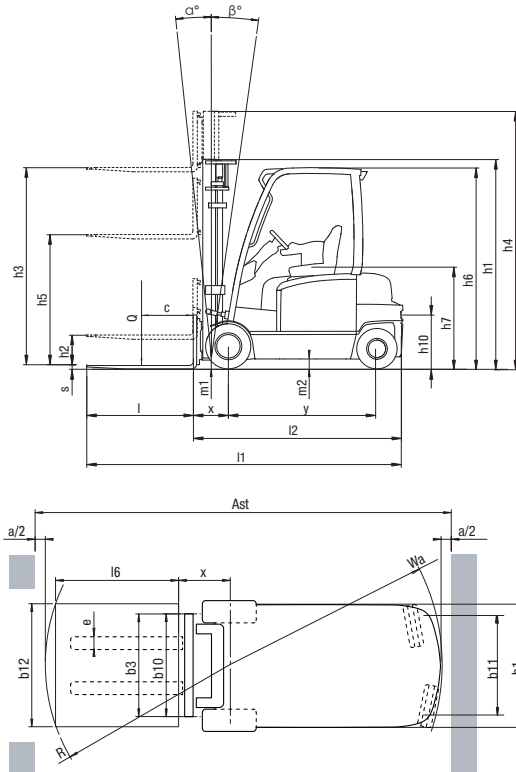

- Ast = $Wa + R + a$
- Ast = Working aisle width
- Wa = Turning radius
- a = Safety clearance = 2×100 mm
- R = $\sqrt{(l6 + x)^2 + (b12 / 2 - b13)^2}$
- b12 = Pallet width (1200 mm)

- h1 = Height with mast lowered
- h2 = Standard free lift
- h3 = Lift height
- h4 = Height with mast raised
- h5 = Full free lift
- Q = Lifting capacity, rated load
- c = Load centre (distance)

MAST TYPE	FB16-20A(C)N					FB16ACN	FB18ACN	FB16AN	FB18AN	FB20AN	
	h3 mm	h1 mm	h4 mm	h2 / h5 mm	tilt angle fwd / rew degrees	Q@ c=500 mm kg	Q@ c=500 mm kg	Q@ c=500 mm kg	Q@ c=500 mm kg	Q@ c=500 mm kg	
	STD		CABIN								
DUPLX	4030	2570	5075	1525	5 / 6	5 / 6	1600	1800	1600	1800	2000

BATTERY DIMENSIONS		18ACN
Battery voltage	V	48
Capacity at a 5-hour discharge	Ah	500 / 625
Battery weight, Min.	kg	679 / 812
Battery weight, Max.	kg	1000 / 1000
BATTERY BOX DIMENSIONS		
Length	mm	522
Width	mm	830 / 1006
Height	mm	627
BATTERY COMPARTMENT SIZE		
Length	mm	532
Width	mm	850 / 1018
Height	mm	690 (660*)

*With battery exchange rolls

